

UP TO 75 HP

MATERIALS

PART NO.	PARTS NAME	MATERIAL
1501	UPPER BEARING HOUSING (COMPLETE)	-
1502	LOWER BEARING HOUSING (COMPLETE)	-
1503	ROTOR	SS316
1504	STATOR	SS316
1507	BEARING BUSH (45 X 55 X 40) MM	CARBON
1508	BEARING BUSH (45 X 55 X 40) MM	CARBON
1508.1	BEARING BUSH RUBBER (45 X 55 X 40) MM	MS/RUBBER
1510	THRUST BEARING SET	CARBON V/S S.S.
1512	DIAPHRAGM PROTECTOR CUP	POM
1513	SPRING	STAINLESS STEEL
1514	SAND GUARD	NBR
1515.1	ADAPTOR	SS316
1516	SEAL GUARD	STAINLESS STEEL
1517	THRUST DISC WITH CARBON	PU COATED GREY IRON / CARBON
1518	THRUST SEGMENT PIECE (QTY-8)	STAINLESS STEEL
1519	THRUST BEARING BASE	PU COATED GREY IRON
1520	COUNTER RING	CLOTH BASED FIBER
1521	DIAPHRAGM	NBR
1523	UPPER WINDING PROTECTOR	PLASTIC
1524	LOWER WINDING PROTECTOR	PLASTIC
1525	WATER PLUG WITH WASHER 1/2" BSP (QTY-2)	SS316
1525A	WATER PLUG WITH 'O' RING	SS316
1526	BEARING SUPPORT	STAINLESS STEEL
1527	MOTOR BASE	STAINLESS STEEL
1528	COUPLE BOLT M16 X 65	SS316
1529	DIAPHRAGM COVER	SS316
1533	SCREW FOR SEAL GUARD M6 X 15 (QTY-4)	STAINLESS STEEL
1535	CIRCLIP DIA. 40	SPRING STEEL
1537	SCREW FOR COUNTER RING M5 X 10 (QTY-3)	STAINLESS STEEL
1538	ALLEN PIN FOR GROMMET M8 X 12 (QTY-2)	SS316
1540	NUT FOR COUPLE STUD M16	SS316
1541	KEY 8 X 12 X 32	STAINLESS STEEL
1542	CABLE KIT	-
1544	'O' RING FOR UPPER STUD 10 X 3 (QTY-4)	RUBBER
1549	ALLEN PIN M5 X 15 (QTY-4)	SS316
1552	STUD FOR MOTOR BASE	STAINLESS STEEL
1555	LOWER WINDING SUPPORTER	RUBBER
1556	WASHER	TEFLON
1557	'O' RING FOR SEAL GUARD 64 X 3	RUBBER
1558	MECHANICAL SEAL	SIC / SIC / NBR
1559	WASHER FOR MECHANICAL SEAL	STAINLESS STEEL
1560	DOME NUT M12 (QTY-4)	SS316
1561	WASHER M12 (QTY-4)	SS316
1562	STUD OR ADAPTOR M12 X 38 (QTY-4)	STAINLESS STEEL
1566	WASHER FOR ALLEN PIN (12.5 X 16 X 1Thk.) (QTY-4)	SS316
1567	'O' RING FOR MOTOR BASE 5 X 1.5 (QTY-4)	NBR

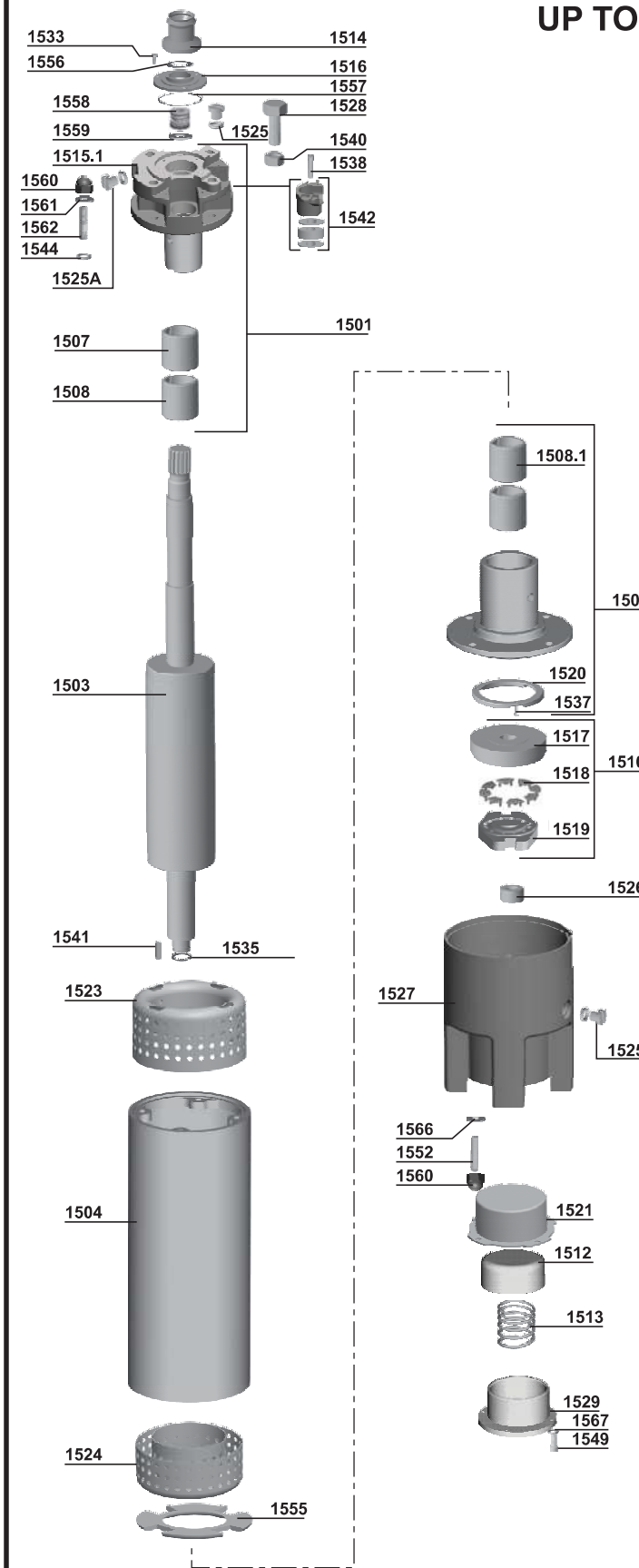

ORDERING NOTE:

While ordering spare parts kindly mention motor type, part no, part name, material & quantity in the order.

100 TO 150 HP

MATERIALS

PART NO.	PARTS NAME	MATERIAL
1501	UPPER BEARING HOUSING (COMPLETE)	-
1502	LOWER BEARING HOUSING (COMPLETE)	-
1503	ROTOR	SS316
1504	STATOR	SS316
1507	BEARING BUSH (50 X 62 X 50) MM	CARBON
1508	BEARING BUSH (50 X 62 X 50) MM	CARBON
1510	THRUST BEARING SET	CARBON V/S S.S.
1512	DIAPHRAGM PROTECTOR CUP	POM
1513	SPRING	STAINLESS STEEL
1514	SAND GUARD	NBR
1515.1	ADAPTOR	SS316
1516	SEAL GUARD	STAINLESS STEEL
1517	THRUST DISC WITH CARBON	PU COATED GREY IRON / CARBON
1518	THRUST SEGMENT PIECE (QTY-8)	STAINLESS STEEL
1519	THRUST BEARING BASE	PU COATED GREY IRON
1520	COUNTER RING	CLOTH BASED FIBER
1521	DIAPHRAGM	NBR
1523	UPPER WINDING PROTECTOR	PLASTIC
1524	LOWER WINDING PROTECTOR	PLASTIC
1525	WATER PLUG WITH WASHER 1/2" BSP (QTY-2)	SS316
1525A	WATER PLUG WITH 'O' RING	SS316
1526	BEARING SUPPORT	STAINLESS STEEL
1527	MOTOR BASE	STAINLESS STEEL
1528	COUPLE BOLT M16 X 65	SS316
1529	DIAPHRAGM COVER	STAINLESS STEEL
1533	SCREW FOR SEAL GUARD M6 X 15 (QTY-4)	STAINLESS STEEL
1535	CIRCLIP DIA. 40	SPRING STEEL
1537	SCREW FOR COUNTER RING M5 X 10 (QTY-3)	STAINLESS STEEL
1538	ALLEN PIN FOR GROMMET M8 X 12 (QTY-2)	SS316
1540	NUT FOR COUPLE STUD M16	SS316
1541	KEY 8 X 12 X 32	STAINLESS STEEL
1542	CABLE KIT	-
1544	'O' RING FOR UPPER STUD 10 X 3 (QTY-4)	RUBBER
1549	ALLEN PIN M5 X 15 (QTY-4)	STAINLESS STEEL
1552	STUD FOR MOTOR BASE	STAINLESS STEEL
1555	LOWER WINDING SUPPORTER	RUBBER
1556	WASHER	TEFLON
1557	'O' RING FOR SEAL GUARD 64 X 3	RUBBER
1558	MECHANICAL SEAL	SIC / SIC / NBR
1560	DOME NUT M12 (QTY-4)	SS316
1561	WASHER M12 (QTY-4)	SS316
1562	STUD OR ADAPTOR M12 X 38 (QTY-4)	STAINLESS STEEL
1566	WASHER FOR ALLEN PIN (12.5 X 16 X 1Thk.) (QTY-4)	SS316
1567	'O' RING FOR MOTOR BASE 5 X 1.5 (QTY-4)	NBR

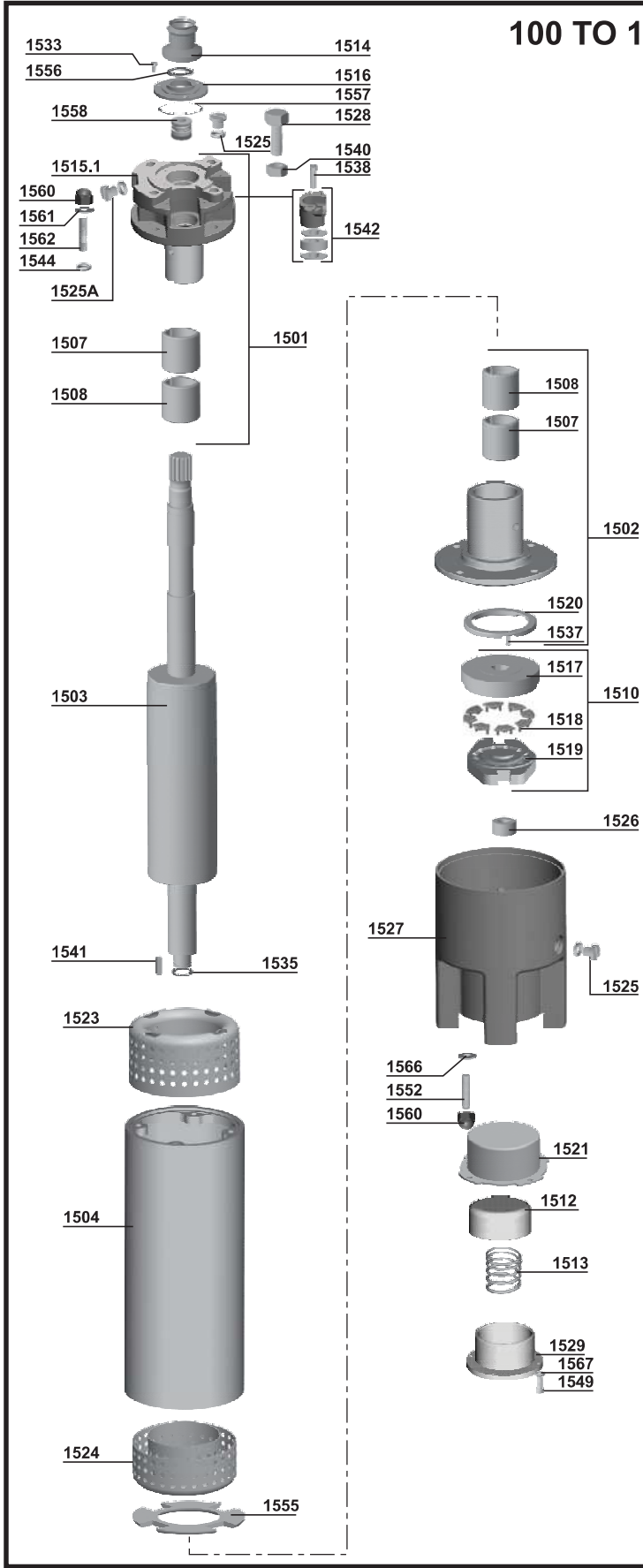

ORDERING NOTE:

While ordering spare parts kindly mention motor type, part no, part name, material & quantity in the order.